



# **HPX-1600 USER GUIDE**

## **Appendix A: Haliplex Cables**

## TABLE OF CONTENTS

<b>1. CABLES.....</b>	<b>1</b>
1.1. ALARM RELAY.....	2
1.2. ETHERNET .....	3
1.3. E1/T1 .....	4
1.4. SERIAL V.24.....	5
1.5. SERIAL V.35.....	6
1.6. SERIAL X.21.....	7
1.7. RS-530.....	9
1.8. VOICE FXS.....	11
1.9. VOICE FXO SERVER .....	12
1.10. VOICE E&M.....	13
1.11. FIBRE OPTIC .....	13

## TABLE OF FIGURES

FIGURE 1 : CONSOLE ETHERNET PIN OUT ..... 3

FIGURE 2 : DB25 FEMALE ..... 5

FIGURE 3 : DB15 X.21 FEMALE ..... 8

FIGURE 4 : – WINCHESTER M34 (V.35 FEMALE) ..... 8

FIGURE 5 – RS-530/RS530A INTERFACE..... 10

FIGURE 6 : VOICE FXS CABLE ..... 11

FIGURE 7 : FIBRE OPTIC IM ..... 13

## LIST OF TABLES

TABLE 1. ALARM RELAY CONTACT RATINGS ..... 2

TABLE 2 : ETHERNET CONSOLE CROSS OVER CABLE TO HPXVIEW PC ..... 3

TABLE 3 – STANDARD T1/E1/J1 NETWORK INTERFACE MODE CABLE PIN-OUTS..... 4

TABLE 4 – STANDARD T1/E1/J1 NETWORK TERMINAL MODE CABLE PIN-OUTS..... 4

TABLE 5 – SERIAL V.24 CABLE ..... 5

TABLE 6 – SERIAL V.35 CABLE ..... 6

TABLE 7 – SERIAL X.21 CABLE ..... 7

TABLE 8 – RS-530/RS-530A CABLE ..... 9

## RECORD OF CHANGES

4.03	Additon	Section 1	“Note: To maintain electromagnetic ...shielded.”
4.03	Amended	Section 1.9	“1.9 Voice FXO Server” Changed whole paragraph

## 1. CABLES

The following section describes the cable specifications for external communication cables for the Haliplex 1600 products.

The sections are written for the HPX-1600 but are equally relevant for all Haliplex Chassis.



Note: Any pins, which are not listed, are not used.



Note: The vertical double end arrows, define cable twisted pairs.



Note: To maintain electromagnetic compatibility, all cables should be shielded.



Caution For continued protection against lightning strikes and accidental connection to hazardous voltages; All external communication cables must meet the minimum conductor size of 26AWG or 0.5 mm<sup>2</sup>. Failure to maintain this minimum conductor standard will breach UL certification for this device.

### 1.1. ALARM RELAY

The "Alarm" section of the front panel, is defined by the grey colour. System alarms are defined with three levels of severity. Each level has an associated relay whose contacts are made available via the RJ11 jack. The contacts are normally open, but closed when the alarm is active. The three LEDs, indicate the alarm status and level of severity. The LEDs are coloured Green, Yellow and Red.

Alarm Relay, Severity Level	RJ11 pins (Relay Contacts)
Green	1 & 2
Yellow	3 & 4
Red	5 & 6

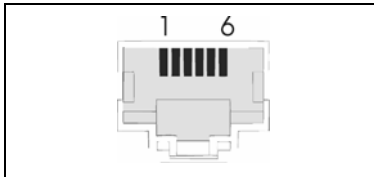

**Figure 1- Alarm relay RJ11 socket (viewed from the HPX-1600 front panel)**

The alarm relay contacts close when the alarm is active.  
 Under normal operation the green relay is closed.  
 If power is removed from the unit, all three of the alarm relays close contacts.

Alarm Relay Contact Rating	
48 V DC nominal	at 1A
60 V DC max	at 1A

**Table 1. Alarm relay contact ratings**

## 1.2. ETHERNET

The RJ45 connector labelled "Ethernet" provides an IP management connection to the HPX-1600. The Ethernet connector carries management information between a local management station and other HPX-1600 family devices at the same location. The Ethernet uses HPXView and SNMP over the IP network protocol to connect the management workstation to the Haliplex nodes. Management access of remote nodes is only possible once the management IP addresses and routing have been configured and are operational.

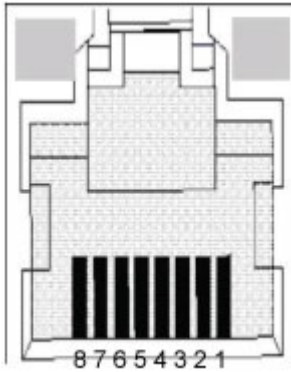

RJ45 pin #	Signal name	Signal name	RJ45 pin #
1	Tx +	Rx +	3
2	Tx -	Rx -	6
3	Rx +	Tx +	1
6	Rx -	Tx -	2

**Table 2 : Ethernet Console Cross Over Cable to HPXView PC**

**Figure 1 : Console Ethernet pin out**

### 1.3. E1/T1

There are two types of cables to connect devices to the HPX-1600 E1/T1 IM, one for Network Interface mode and the other for Network Terminal mode of operation. Each cable connects to the IM, 8 pin RJ45 connector.



**Note:**

The single port E1/T1 IM has two RJ45 connectors. Use only the uppermost or top RJ45 connector on the IM. The lower RJ45 is not used.

The Dual E1 and Dual T1 IM, use both the RJ45 connectors.

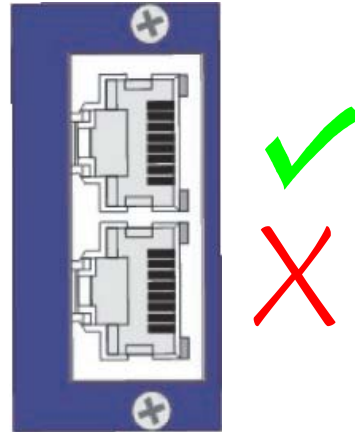

**Note:** Unused pins are not connected at the HPX-1600 IM. The metal shell of the RJ45 socket may optionally be used as shield.

HPX-1600 Cable 006 Network Interface Mode			
P1 RJ45	Signal Name	P2 RJ45	Signal Name
1	Tx Tip	4	Rx Tip
2	Tx Ring	5	Rx Ring
3			
4	Rx Tip	1	Tx Tip
5	Rx Ring	2	Tx Ring
6			
7			
8			

Table 3 – Standard T1/E1/J1 Network Interface Mode Cable Pin-Outs

HPX-1600 Cable 007 Network Terminal Mode			
P1 RJ45	Signal Name	P2 RJ45	Signal Name
1	Tx Tip	1	Tx Tip
2	Tx Ring	2	Tx Ring
3		3	
4	Rx Tip	4	Rx Tip
5	Rx Ring	5	Rx Ring
6		6	
7		7	

Table 4 – Standard T1/E1/J1 Network Terminal Mode Cable Pin-Outs

### 1.4. SERIAL V.24

There are two types of cables to connect V.24 devices to the HPX-1600 IM, one for DTE and the other for DCE mode of operation. Each cable connects to the IM 50pin VHDCI and provides two DB25, V.24 connectors.

HPX-1600 Cable 004 DCE Mode				
P1	P2	P3	Circuit Abrev.	ITU-T
50pin VHDCI male	DB25 female	DB25 female		
1	2		BA, TXD	103
3	3		BB, RXD	104
5	24		DA, SCTE	113
7	17		DD, RXC	115
9	15		DB, TXC	114
11	5		CB, CTS	106
13	4		CA, RTS	105
15	20		CD, DTR	108.2
17	6		CC, DSR	107
19	8		CFC, DCD	109
21	18		LL, LL	
22	21		RL, RL	
25	7		AB, GND	102
26		3	BB, RXD	104
27		2	BA, TXD	103
30		17	DD, RXC	115
31		24	DA, SCTE	113
34		15	DB, TXC	114
35		5	CB, CTS	106
38		4	CA, RTS	105
39		6	CC, DSR	107
42		20	CD, DTR	108.2
43		8	CFC, DCD	109
46		18	LL, LL	
48		21	RL, RL	
50		7	AB, GND	102

HPX-1600 Cable 005 DTE Mode				
P1	P2	P3	Circuit Abrev.	ITU-T
50pin VHDCI male	DB25 male	DB25 male		
1	3		BB, RXD	104
3	2		BA, TXD	103
5	17		DD, RXC	115
7	24		DA, SCTE	113
9	15		DB, TXC	114
11	4		CA, RTS	105
13	5		CB, CTS	106
15	6		CC, DSR	107
17	20		CD, DTR	108.2
19	8		CFC, DCD	109
21	18		LL, LL	
23	21		RL, RL	
25	7		AB, GND	102
26		2	BA, TXD	103
27		3	BB, RXD	104
30		24	DA, SCTE	113
31		17	DD, RXC	115
34		15	DB, TXC	114
35		4	CA, RTS	105
38		5	CB, CTS	106
39		20	CD, DTR	108.2
42		6	CC, DSR	107
43		8	CFC, DCD	109
46		18	LL, LL	
47		21	RL, RL	
50		7	AB, GND	102

Table 5 – Serial V.24 Cable

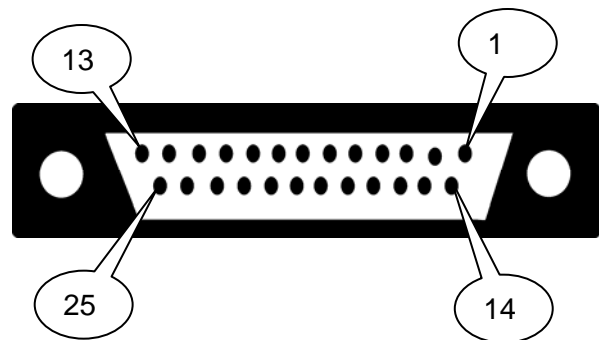

Figure 2 : DB25 Female

### 1.5. SERIAL V.35

There are two types of cables to connect V.35 devices to the HPX-1600 IM, one for DTE and the other for DCE mode of operation. Each cable connects to the IM 50pin VHDCI and provides two M34(Winchester), V.35 connectors.

HPX-1600 Cable 002 DCE Mode				
P1	P2	P3		
50pin VHDCI male	M34 female	M34 female	CCITT#	Circuit Name
1	P		103	TXD
2	S		103	TXD
3	R		104	RXD
4	T		104	RXD
5	U		113	TTC
6	W		113	TTC
7	V		115	RXC
8	X		115	RXC
9	Y		114	TXC
10	AA		114	TXC
11	D		106	CTS
13	C		105	RTS
15	H		108	DTR
17	E		107	DSR
19	F		109	RLSD
21	L		141	LL
22	N		140	RL
23	NN		142	TM
25	B		102	GND
26		R	104	RXD
27		P	103	TXD
28		T	104	RXD
29		S	103	TXD
30		V	115	RXC
31		U	113	TTC
32		X	115	RXC
33		W	113	TTC
34		Y	114	TXC
35		D	106	CTS
36		AA	114	TXC
38		C	105	RTS
39		E	107	DSR
42		H	108	DTR
43		F	109	RLSD
46		L	141	LL
47		NN	142	TM
48		N	140	RL
50		B	102	GND

HPX-1600 Cable 003 DTE Mode				
P1	P2	P3		
50pin VHDCI male	M34 male	M34 male	CCITT#	Circuit Name
1	R		104	RXD
2	T		104	RXD
3	P		103	TXD
4	S		103	TXD
5	V		115	RXC
6	X		115	RXC
7	U		113	TTC
8	W		113	TTC
9	Y		114	TXC
10	AA		114	TXC
11	C		105	RTS
13	D		106	CTS
15	E		107	DSR
17	H		108	DTR
19	F		109	RLSD
21	L		141	LL
22	NN		142	TM
23	N		140	RL
25	B		102	GND
26		P	103	TXD
27		R	104	RXD
28		S	103	TXD
29		T	104	RXD
30		U	113	TTC
31		V	115	RXC
32		W	113	TTC
33		X	115	RXC
34		Y	114	TXC
35		C	105	RTS
36		AA	114	TXC
38		D	106	CTS
39		H	108	DTR
42		E	107	DSR
43		F	109	RLSD
46		L	141	LL
47		N	140	RL
48		NN	142	TM
50		B	102	GND

Table 6 – Serial V.35 Cable

### 1.6. SERIAL X.21

There are two types of cables to connect X.21 devices to the HPX-1600 IM, one for DTE and the other for DCE mode of operation. Each cable connects to the IM 50pin VHDCI and provides two DB15, X.21 connectors.

HPX-1600 Cable 000 DCE Mode			
P1	P2	P3	Circuit name
50pin VHDCI male	DB15 female	DB15 female	
1	2		T(A) ↓↑
2	9		T(B) ↓↑
3	4		R(A) ↓↑
4	11		R(B) ↓↑
5	7		X(A) ↓↑
6	14		X(B) ↓↑
7	6		S(A) ↓↑
8	13		S(B) ↓↑
11	5		I(A) ↓↑
12	12		I(B) ↓↑
13	3		C(A) ↓↑
14	10		C(B) ↓↑
25	8		G
26		4	R(A) ↓↑
27		2	T(A) ↓↑ ↓↑
28		11	R(B) ↓↑ ↓↑
29		9	T(B) ↓↑ ↓↑
30		6	S(A) ↓↑ ↓↑
31		7	X(A) ↓↑ ↓↑
32		13	S(B) ↓↑ ↓↑
33		14	X(B) ↓↑ ↓↑
35		5	I(A) ↓↑
37		12	I(B) ↓↑
38		3	C(A) ↓↑
40		10	C(B) ↓↑
50		8	G

HPX-1600 Cable 001 DTE Mode			
P1	P2	P3	Circuit name
50pin VHDCI male	DB15 male	DB15 male	
1	4		R(A) ↓↑
2	11		R(B) ↓↑
3	2		T(A) ↓↑
4	9		T(B) ↓↑
5	6		S(A) ↓↑
6	13		S(B) ↓↑
7	7		X(A) ↓↑
8	14		X(B) ↓↑
11	3		C(A) ↓↑
12	10		C(B) ↓↑
13	5		I(A) ↓↑
14	12		I(B) ↓↑
25	8		G
26		2	T(A) ↓↑ ↓↑
27		4	R(A) ↓↑ ↓↑
28		9	T(B) ↓↑ ↓↑
29		11	R(B) ↓↑ ↓↑
30		7	X(A) ↓↑ ↓↑
31		6	S(A) ↓↑ ↓↑
32		14	X(B) ↓↑ ↓↑
33		13	S(B) ↓↑ ↓↑
35		3	C(A) ↓↑
37		10	C(B) ↓↑
38		5	I(A) ↓↑
40		12	I(B) ↓↑
50		8	G

Table 7 – Serial X.21 Cable

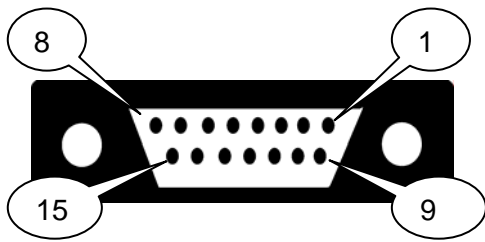

Figure 3 : DB15 X.21 Female

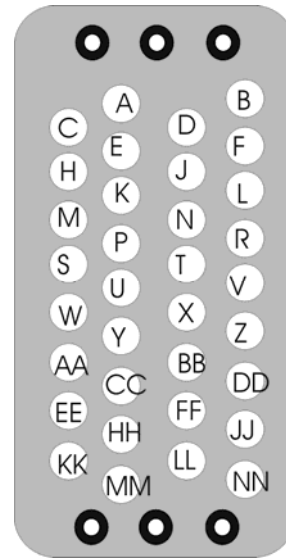

Figure 4 : – Winchester M34 (V.35 Female)

1.7. RS-530

HPX-CAB-RS530-DCE			
P1	"A" port	"B" port	
50pin VHDCI	DB25 female	DB25 female	Circuit Abbrev.
1	2		BA(A), TXD
2	14		BA(B), TXD
3	3		BB(A), RXD
4	16		BB(B), RXD
5	24		DA(A), SCTE
6	11		DA(B), SCTE
7	17		DD(A), RXC
8	9		DD(B), RXC
9	15		DB(A), TXC
10	12		DB(B), TXC
11	5		CB(A), CTS
12	13		CB(B), CTS
13	4		CA(A), RTS
14	19		CA(B), RTS
15	20		CD(A), DTR
16	23		CD(B), DTR
17	6		CC(A), DSR
18	22		CC(B), DSR
19	8		CF(A), DCD
20	10		CF(A), DCD
21	18		LL, LL
22	21		RL, RL
25	7		AB, GND
26		3	BB(A), RXD
28		16	BB(B), RXD
27		2	BA(A), TXD
29		14	BA(B), TXD
30		17	DD(A), RXC
32		9	DD(B), RXC
31		24	DA(A), SCTE
33		11	DA(B), SCTE
34		15	DB(A), TXC
36		12	DB(B), TXC
35		5	CB(A), CTS
37		13	CB(B), CTS
38		4	CA(A), RTS
40		19	CA(B), RTS
39		6	CC(A), DSR
41		22	CC(B), DSR
42		20	CD(A), DTR
44		23	CD(B), DTR
43		8	CF(A), DCD
45		10	CF(B), DCD
46		18	LL, LL
48		21	RL, RL
50		7	AB, GND

HPX-CAB-RS530-DTE			
P1	"A" port	"B" port	
50pin VHDCI	DB25 male	DB25 male	Circuit Abbrev.
1	3		BB(A), RXD
2	16		BB(B), RXD
3	2		BA(A), TXD
4	14		BA(B), TXD
5	17		DD(A), RXC
6	9		DD(B), RXC
7	24		DA(A), SCTE
8	11		DA(B), SCTE
9	15		DB(A), TXC
10	12		DB(B), TXC
11	4		CA(A), RTS
12	19		CA(B), RTS
13	5		CB(A), CTS
14	13		CB(B), CTS
15	6		CC(A), DSR
16	22		CC(B), DSR
17	20		CD(A), DTR
18	23		CD(B), DTR
19	8		CF(A), DCD
20	10		CF(B), DCD
21	18		LL, LL
23	21		RL, RL
25	7		AB, GND
26		2	BA(A), RXD
28		14	BA(B), RXD
27		3	BB(A), TXD
29		16	BB(B), TXD
30		24	DA(A), RXC
32		11	DA(B), RXC
31		17	DD(A), SCTE
33		9	DD(B), SCTE
34		15	DB(A), TXC
36		12	DB(B), TXC
35		4	CA(A), RTS
37		19	CA(B), RTS
38		5	CB(A), CTS
40		13	CB(B), CTS
39		20	CD(A), DSR
41		23	CD(B), DSR
42		6	CC(A), DTR
44		22	CC(B), DTR
43		8	CF(A), DCD
45		10	CF(B), DCD
46		18	LL, LL
47		21	RL, RL
50		7	AB, GND

Table 8 – RS-530/RS-530A Cable

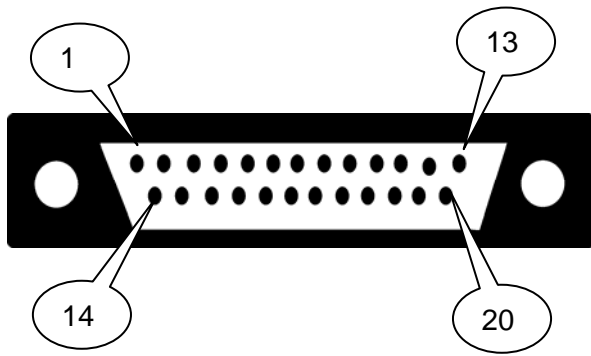

**Figure 5 – RS-530/RS530A Interface**

### 1.8. VOICE FXS

The two port FXS (Foreign Exchange Station) voice IM is used to connect to an analogue telephone, fax machine, modem or similar device. The FXS IM has a RJ45 socket for each voice circuit. Only the two centre pins, (4 & 5) are used. This equates to pins 3 and 4 of a RJ11 plug, which may be plugged directly into the centre of the RJ45 socket.

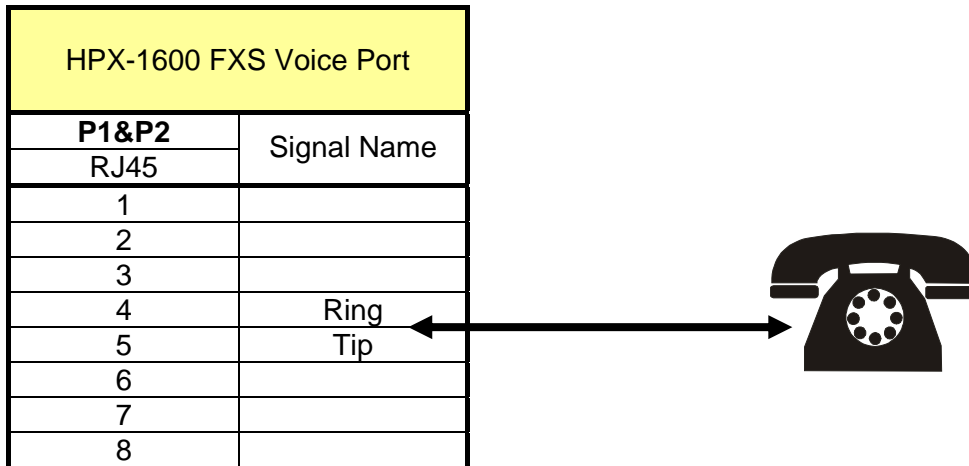

Figure 6 : Voice FXS Cable

## 1.9. VOICE FXO SERVER

The FXO (Outdoor Extension) is used to connect to a PBX, CO or telephone exchange switch. An FXO interface module was previously not available so a non-IM solution, with dimensions similar to a HPX-1600 (1 rack unit) was provided. The FXO server was available in multiples of 6. (6, 12, 18 . . . etc) The cable that connects from the FXO server has a 50pin CHAMP connector at one end and the other end should be terminated in a "punch-down" block.

Circuit 1	Pin 1 = R	Pin 26 = T
	Pin 2 = Not connected	Pin 27 = Not connected
Circuit 2	Pin 3 = R	Pin 28 = T
	Pin 4 = Not connected	Pin 29 = Not connected
Circuit 3	Pin 5 = R	Pin 30 = T
	Pin 6 = Not connected	Pin 31 = Not connected
Circuit 4	Pin 7 = R	Pin 32 = T
	Pin 8 = Not connected	Pin 33 = Not connected
Circuit 5	Pin 9 = R	Pin 34 = T
	Pin 10 = Not connected	Pin 35 = Not connected
Circuit 6	Pin 11 = R	Pin 36 = T
	Pin 12 = Not connected	Pin 37 = Not connected
Circuit 7	Pin 13 = R	Pin 38 = T
	Pin 14 = Not connected	Pin 39 = Not connected
Circuit 8	Pin 15 = R	Pin 40 = T
	Pin 16 = Not connected	Pin 41 = Not connected
Circuit 9	Pin 17 = R	Pin 42 = T
	Pin 18 = Not connected	Pin 43 = Not connected
Circuit 10	Pin 19 = R	Pin 44 = T
	Pin 20 = Not connected	Pin 45 = Not connected
Circuit 11	Pin 21 = R	Pin 46 = T
	Pin 22 = Not connected	Pin 47 = Not connected
Circuit 12	Pin 23 = R	Pin 48 = T
	Pin 24 = Not connected	Pin 49 = Not connected
Spare line	Pin 25 = Frame Ground	Pin 50 = Frame Ground

**Table 7 : Cable 011 - FXO server**

### 1.10. VOICE E&M

The E&M IM has two ports, each terminated in an RJ45 socket. E & M or "Ear and Mouth" is a signalling technique for connecting telephone and trunk services to telephone exchanges and related equipment such as remote radio transmitters. The voice circuit may be two wire, or full duplex, four wire and will be defined by the exchange equipment interface. The table below describes the pin usage for each mode of operation.

P1&P2 RJ45	Signal Name	2 Wire Operation					4 Wire Operation					Signal Description
		E&M Type					E&M Type					
		1	2	3	4	5	1	2	3	4	5	
1	SB		SB	SB	SB			SB	SB	SB		-48VDC
2	M-Lead	M	M	M	M	M	M	M	M	M	M	Signalling in
3	R						R	R	R	R	R	Ring Audio
4	R or R1	R	R	R	R	R	R1	R1	R1	R1	R1	Ring Audio
5	T or T1	T	T	T	T	T	T1	T1	T1	T1	T1	Tip Audio
6	T						T	T	T	T	T	Tip Audio
7	E-Lead	E	E	E	E	E	E	E	E	E	E	Signalling out
8	SG		SG	SG	SG			SG	SG	SG		Sig. Ground

Table 8 – Voice E&M Cable

### 1.11. FIBRE OPTIC

The Fibre Optic IM is available in several variants of bandwidth and termination connector. Check the model number for details. Connectors may be either SC-APC or FC-PC. All the Fibre Optic IM models have two fibre optic connectors on the front of the IM.

The top connector is used for Receive, the lower connector for Transmit.

Each Fibre Optic trunk runs in Duplex mode, and requires two Single Mode fibres.

Fibre Optic conductor specifications;  
 9µm core  
 125µm cladding

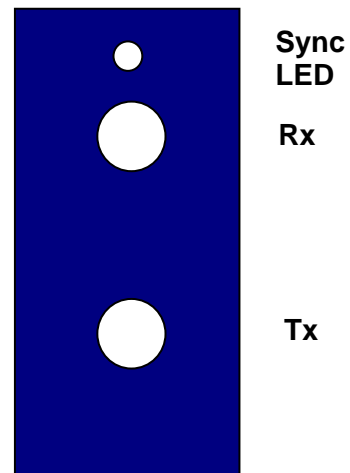

Figure 7 : Fibre Optic IM