



HPX-1600 USER GUIDE

Chapter 3-8: E3-DS3 Mux – Tributary Connections

TABLE OF CONTENTS

- 1. INTRODUCTION..... 1**
 - 1.1. APPLICATIONS..... 1

- 2. TRIBUTARY CONFIGURATION USING HPXVIEW 2**
 - 2.1. CONFIGURE THE VC & VT BANDWIDTH 3
 - 2.2. CONFIGURE THE MULTIPLEXER MODULE..... 4
 - 2.3. SDH / SONET CROSS CONNECT 5
 - 2.3.1. CONTROL - BUTTONS 6
 - 2.3.2. CONTROL - MENU..... 6
 - 2.3.3. TAILOR THE SCREEN APPEARANCE 7

TABLE OF FIGURES

FIGURE 1 : ET3M AS AN INTERCONNECT TRUNK.....	1
FIGURE 2 : SPUR TRUNK: SPLIT BOTH EAST AND WEST.....	1
FIGURE 3 - HPXVIEW TO HPX-1600-SS	2
FIGURE 4 : SDH VC TYPE SELECTION	3
FIGURE 5 : SONET VT TYPE SELECTION.....	4
FIGURE 6 : RED CONNECTION POINTS INDICATE CONFIGURATION CONFLICT	4
FIGURE 7: SDH TRIBUTARY CONNECTIONS.....	5
FIGURE 8 : RIGHT CLICK MENU	6
FIGURE 9 : GREEN DRAG HANDLES	7

1. INTRODUCTION

The Haliplex HPX-IM-1632 is a PDH multiplexer in an interface module. This interface module multiplexes up to 16, 21 or 28 T1 or E1 circuits from the SDH/SONET trunk into an E3/DS3 electrical interface. HPX-1600-SS product, supports multiplexing of E1/T1 and E3/T3 tributary circuits over SDH/SONET networks. Connection management is by the Windows application HPXView. This chapter describes the specific features of HPXView used to map the ET3M interface module into SDH/SONET, STM-1/OC-3 payloads.

1.1. APPLICATIONS

The flexible configuration capability of the ET3M interface module supports these application benefits:

- 15 more E1 circuits can be carried over an SDH STM-1 trunk than if the E3 circuit was mapped directly over the SDH trunk.
- E1 or T1 tributaries can be connected between SDH and SONET networks.
- Fractional E3 or DS3 circuits allow greater network flexibility.
- E1 or T1 circuits from both East and West directions in a SDH/SONET network can be multiplexed in a single spur trunk.

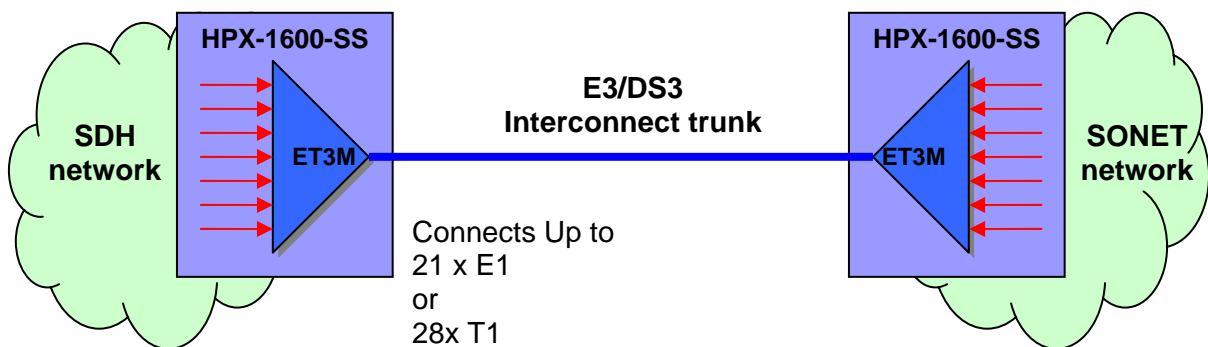

Figure 1 : ET3M as an Interconnect trunk

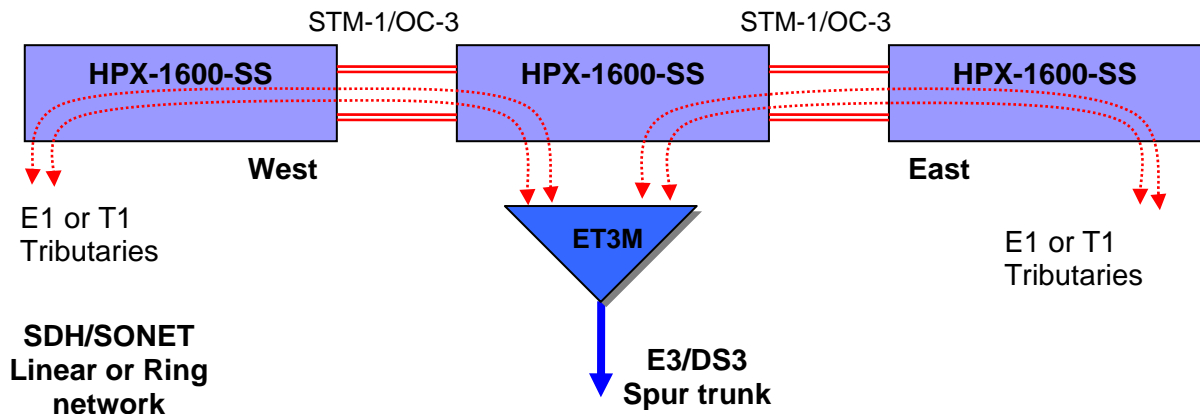

Figure 2 : Spur trunk: Split both East and West

2. TRIBUTARY CONFIGURATION USING HPXVIEW

Connect the HPXView session to the target HPX-1600-SS via serial port or TCP/IP over Ethernet. A successful connection will result in the display of a window similar to that below.

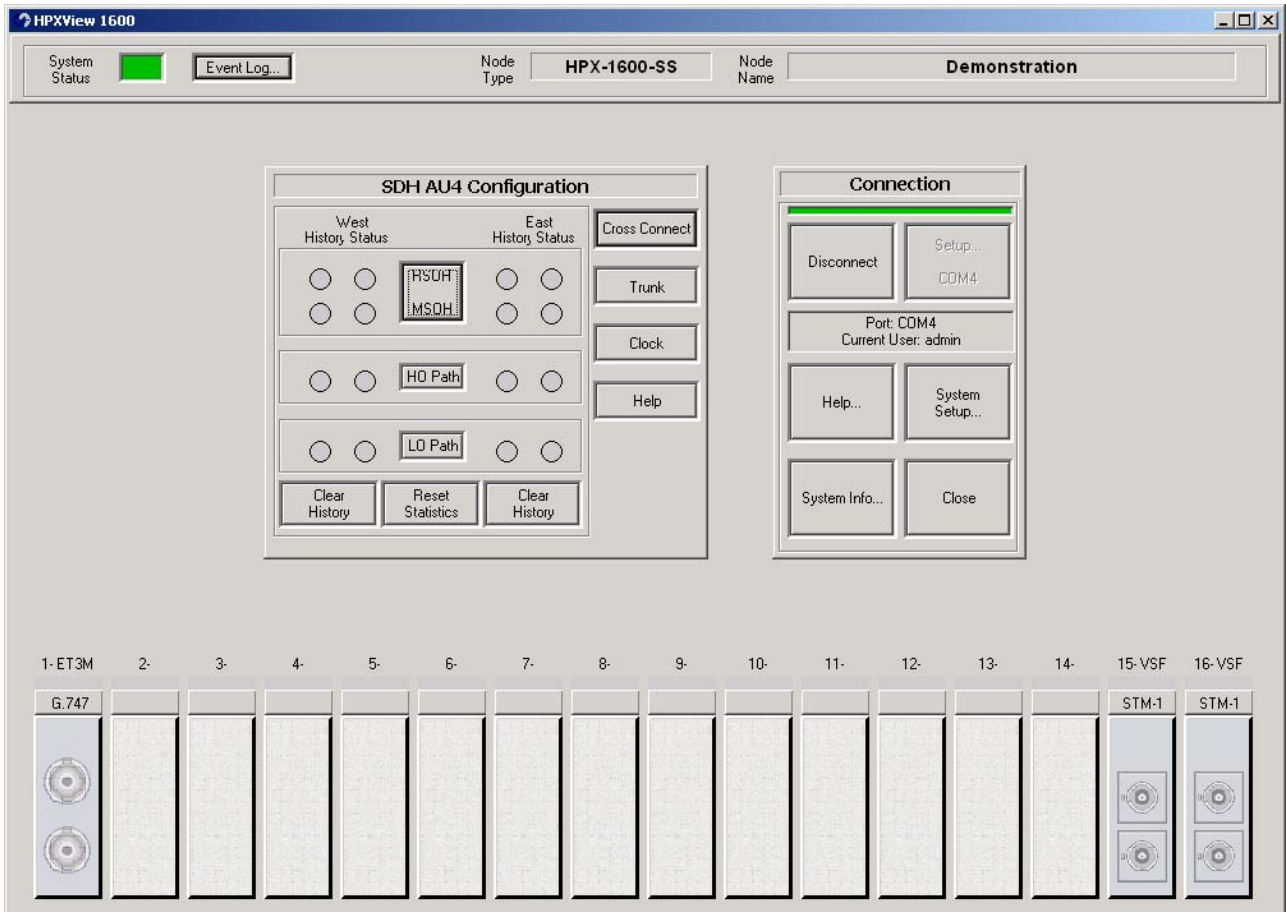

Figure 3 - HPXView to HPX-1600-SS

To manage the tributary connections to the trunk, click on the "Cross Connect" button to display a window similar to that in Figure 7.

2.1. CONFIGURE THE VC & VT BANDWIDTH

The HPX-1600-SS has default settings of virtual container or virtual tributary which are displayed in the cross connect window the first time a node configuration is commenced. These are;

For SDH (AU-4)

- 3x TU-3, (represented by the grey bars) which each contain;
 - 7x TU-2 (represented by coloured sub frame) which each contain;
 - 3x TU-12 (represented as white squares) which each contain an E1 payload
 - 4x TU-11 (represented as white squares) each containing an E1 payload.

For SONET

- 3x STS-1, (represented by the grey bars) which each contain;
 - 7x VT-6 (represented by coloured sub frame) which each contain;
 - 3x VT-2 (represented as white squares) each containing a T1 payload.
 - 4x VT1.5 (represented as white squares) each containing a T1 payload.

To change the VC/VT bandwidth, Right-click on a white square that represents a VC/VT, select “Tributary type”, then select the required tributary type. The change will be immediately displayed in the graphic.

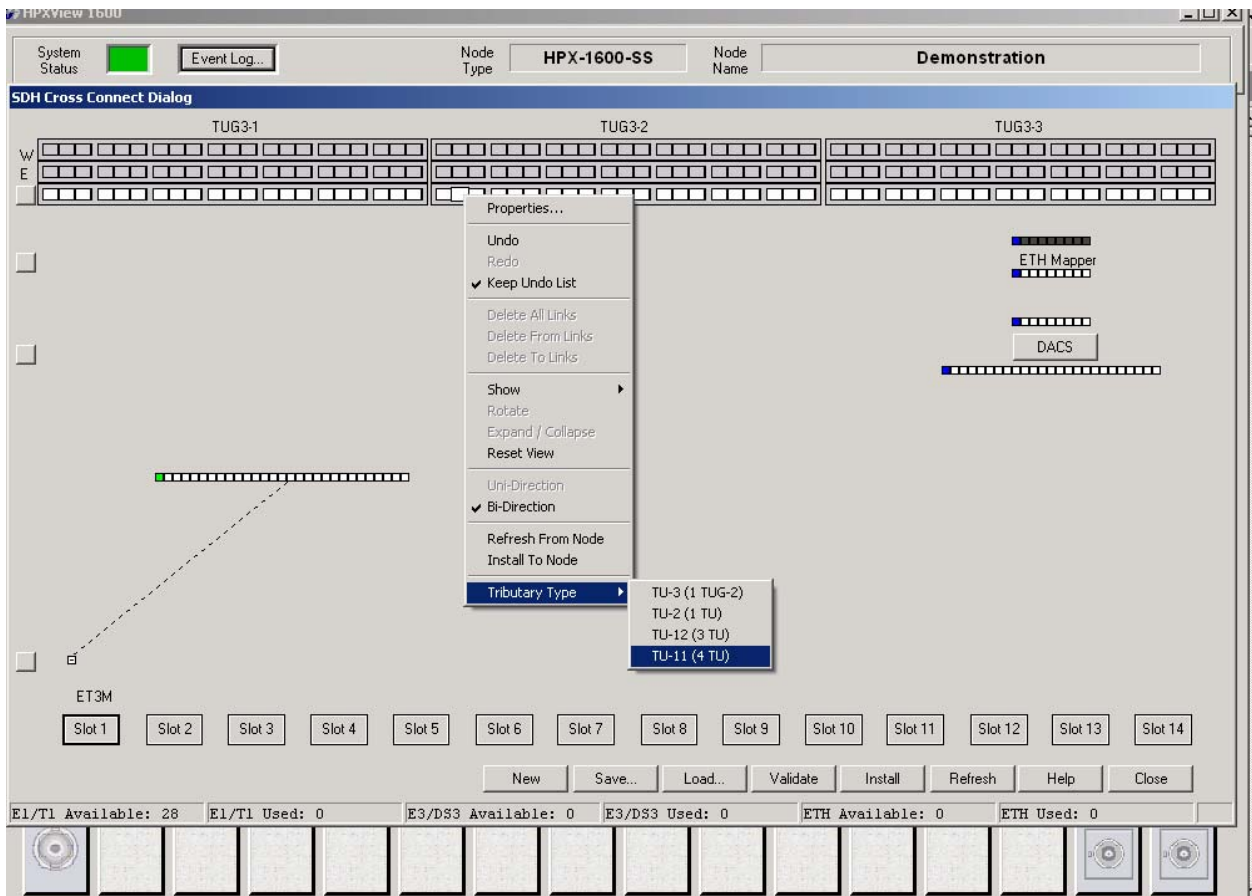

Figure 4: SDH VC type selection

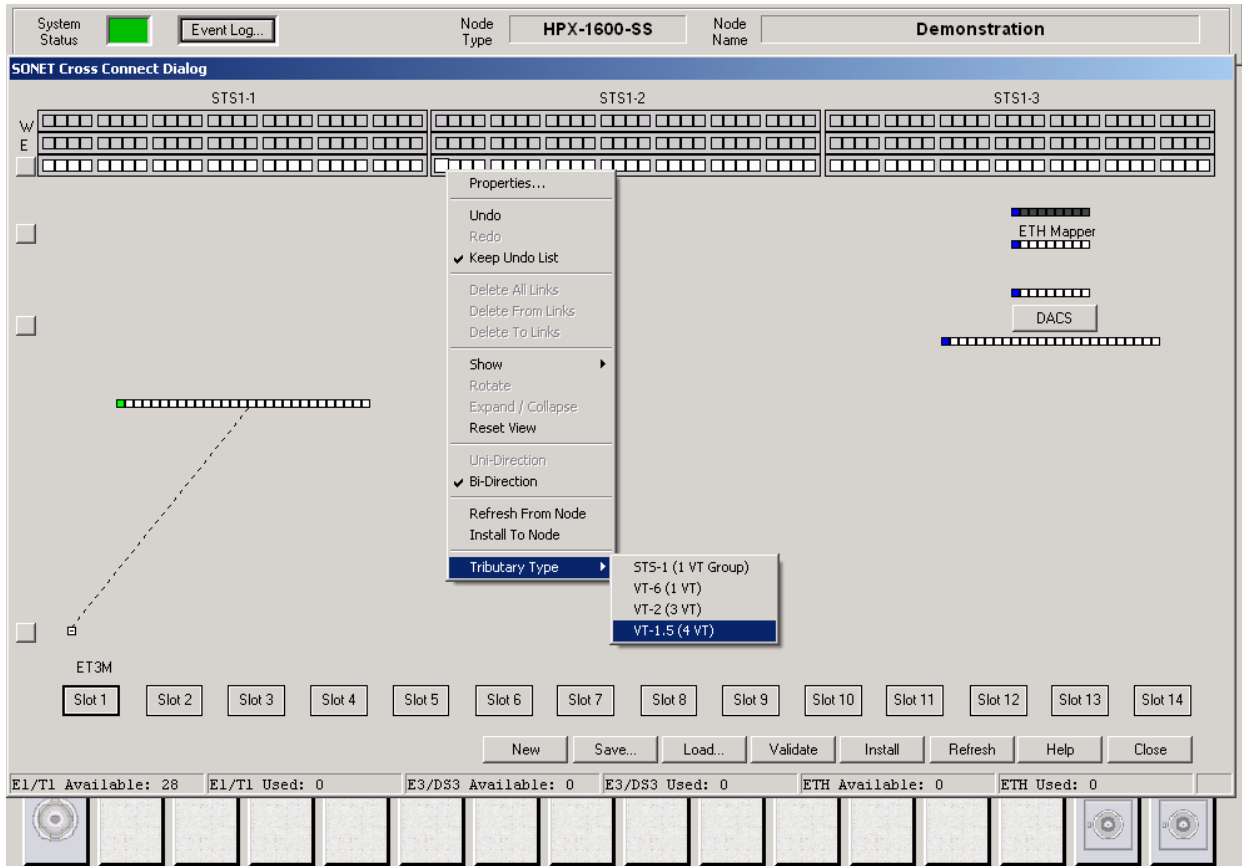
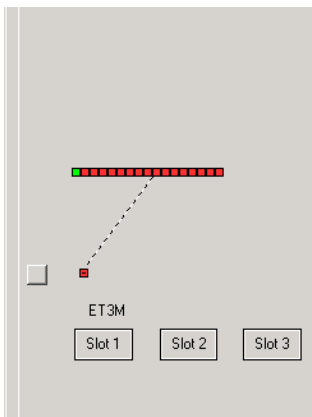

Figure 5 : SONET VT type selection

2.2. CONFIGURE THE MULTIPLEXER MODULE

The ET3M interface module should be configured for the required multiplexer capacity before the SDH/SONET cross connect is configured. Changing the number of virtual tributaries in the interface module also changes the corresponding number of connection boxes in the SDH/SONET cross connect window. The number of virtual tributary connection boxes will be one of 16, 21 or 28.



If the ET3M configuration is changed from within the cross connect window and the number of virtual tributary changes, the tributary boxes will be coloured red to indicate a configuration conflict. The conflict state can be corrected by clicking on the “Validate” button, however this will delete any existing cross connects to the ET3M module.

Figure 6 : Red connection points indicate configuration conflict

2.3. SDH / SONET CROSS CONNECT

To cross connect the E1 or T1 tributary of the ET3M interface simply click on the E1/T1 tributary icon and drag to the destination trunk circuit choice. The three TUG3-x grey coloured bars at the top of the screen represent the maximum tributary unit payload of 63x E1 tributaries or 84 x T1 tributaries for a STM-1/OC-3 trunk.

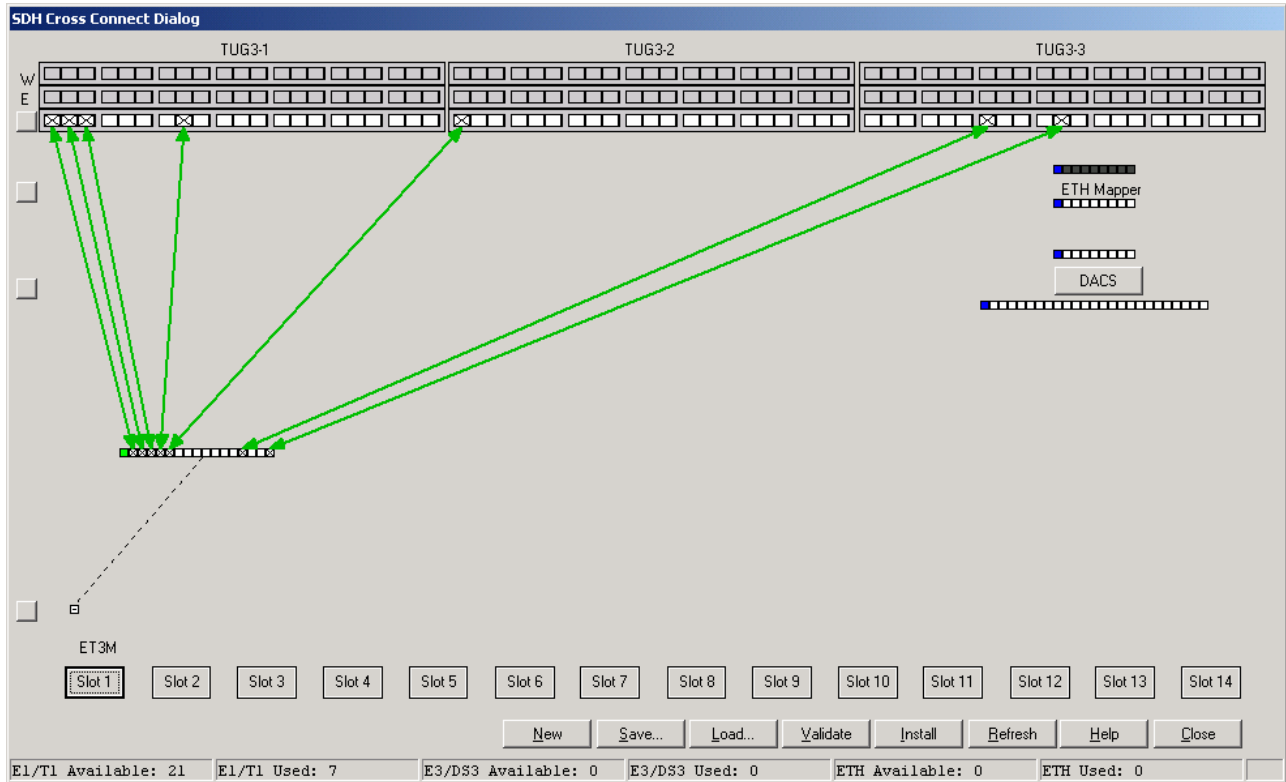

Figure 7: SDH tributary connections

The grey coloured TUG3 structure at the top of the screen may be represented by either two or three rows of TUG3s. If no trunk protection circuits exist, then there will be two rows, else there will be three rows. The top two rows represent either the “Working” and “Protection” trunks or the “East” and “West” trunks depending on the network topology terminal, linear or ring.

The lowest row of white squares represents the local termination of the tributary units.

2.3.1. CONTROL - BUTTONS

The SDH/SONET Cross Connect window has these feature buttons;

- NEW** Deletes the current cross connect.
- SAVE** Prompts for a filename to save the current cross connect to disk.
- LOAD** Prompts for a filename of a previously saved cross connect.
- VALIDATE** Verifies the cross connections to IMs actually exist.
- INSTALL** Uploads the current PC cross connect to the HPX-1600-SS.
- REFRESH** Downloads the current HPX-1600-SS to the PC.

2.3.2. CONTROL - MENU

A Right click in the grey area of the SDH/SONET cross connect window, displays the drop down menu as in Figure 8.

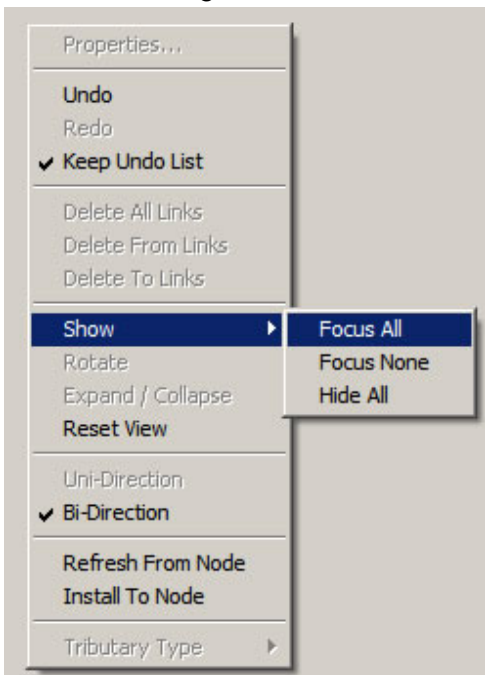

This menu allows repetitive Undo and Redo of cross connects up to a maximum of 40 actions.

To delete a specific cross-connect, right click directly on either end of a link, then select "Delete All Links" from the menu. This will delete only the selected link.

A complex cross connect window can be clarified by focussing on only the components being addressed. The Interface Module, DACS, TU and Ethernet-Mapper can be faded or focussed from the drop down menu or by the four check boxes on the left margin of the window as depicted in Figure 8.

Figure 8 : Right click menu

2.3.3. TAILOR THE SCREEN APPEARANCE

The ET3M virtual tributary icons can be moved to any location of the window by dragging the “green handle” at the edge of each icon. Double clicking on the “green handle” will rotate the tributary icon bar 90 degrees clockwise. Clicking on the “Install” button will save the new screen location of this icons with the cross connect to the connected node.

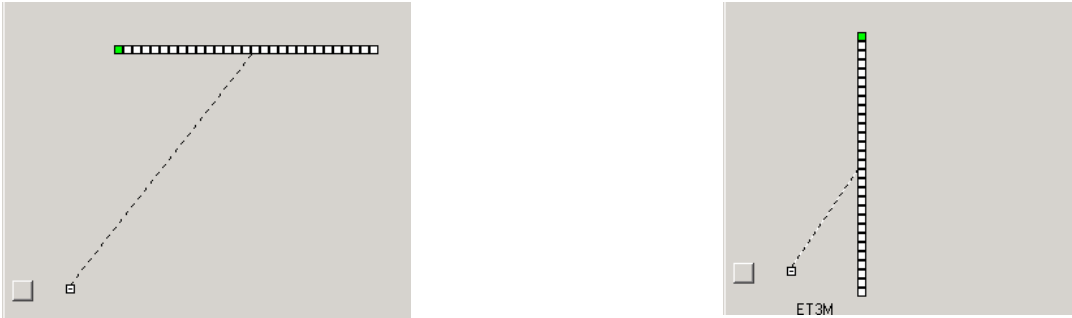

Figure 9 : Green drag handles

Tributary #1 is always represented by the white square closest to the “green handle”. Holding the mouse over any tributary square will report the tributary number.